

NO.	QTY.	PART#	PART DESCRIPTION
1	2		Door Panels
2	1	A1010*	Top Channel
3	1	A2020*	Bottom Track
4	1	W0101	Wood Strip
5	6	S0095*	#8 x 1-1/2" PH SMS Screw
6	4	S0055*	#8 x 1/2" Truss Screw
7	2	B0101	Clear Bumper
8	4	N2030	Concrete Nails
9	4	N1030	5 Penny Nails
10	4	W0900	Side Mold
11	4	W0900	Top and Bottom Mold
12	4	W8020	Steel Wheel Assembly
13	4	G1000	Nylon Top Guide
14	12	S0500	Staples
15	8	S0097	#8 x 3/4" HWH ASMS Screw
16	8	S0160*	#8 x 3/4" HWH ASMS Screw

*When reordering the part please indicate the SIZE and/or COLOR

Universal Bi-Pass Wardrobe Doors Illustrated Installation Instructions



Quality.

"We Set The Standard."

Congratulations on purchasing your new Cw® wardrobe door. Now that you have opened the package, we want you to verify that you have all the necessary hardware supplied with your door(s).

Parts check list:

Part Description

- Door Panels
- Top Channel
- Bottom Track
- Wood Strip (located inside of Track)
- #8 x 1 1/2" Screws
- #8 x 1/2" Screws
- Clear Plastic Bumpers
- Concrete Nails
- Penny Nails
- Mirror Handles (not included with all models)
- Mirror/Painted Glass Fascia (not included with all models)
- Top Guides (not included with all models)

Note: Based upon application and/or panels used, the quantities and parts may vary. If you find that any parts are damaged or missing, please contact our Customer Service department at 661.257.1177.

Make sure that you have all the proper tools required to install your new wardrobe door.

Tool check list (not included):

- Safety glasses and gloves
- Phillips screwdriver
- Tape measure
- Pencil
- Utility knife
- Electric drill
- Masonry drill bit set (see **Step 3, A3**)
- Drill bit set
- Miter box and hacksaw (with 32-tooth blade)
- Square
- Construction adhesive (see **Step 3, A2-3**)
- Screws and screw anchors (see **Step 3, A3**)

Note: Views and directions given in these instructions i.e., left, right, front, back, etc., are from the outside facing the wardrobe door or opening.

Step 1 Preparing your opening

Remove existing doors, brackets, top channel and bottom track. Your opening should be free of any clutter and debris. Ensure the area for the Top Channel has been prepped and ready for installation.

Step 2 Installing the Top Channel

A. Measure the opening at the top, from wall to wall.

B. Cut the Top Channel to the dimension you measured, using a miter box and hacksaw for a straight cut. Cut one end only.

Note: If your closet has wall jambs you may need to notch your Top Channel on each end.

C. When cut to proper length, install Top Channel up to the top front of closet opening making sure that the front of the Top Channel is flush with outside walls. Hold up the Top Channel in the desired position and with your pencil, mark where the pre-drilled holes are in the Top Channel (See **Figure 1**).

Note: If installing a Mirror or Painted Glass Fascia, install the Top Channel 1/4" back from outside wall to leave room for the Fascia.

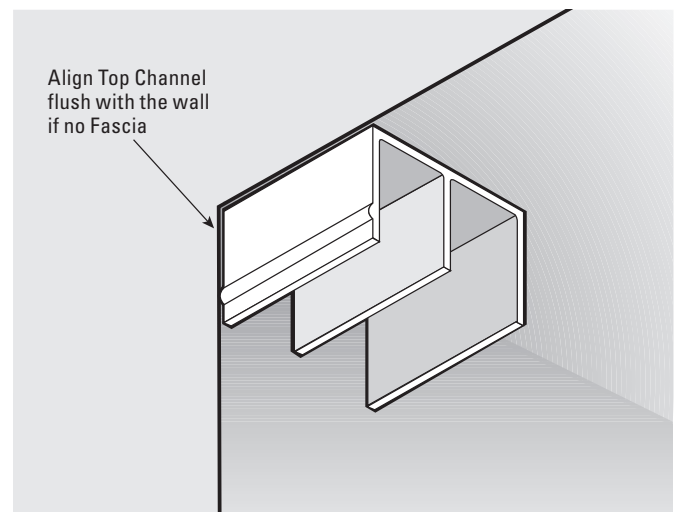

Figure 1

D. Remove the Top Channel and drill pilot holes using 1/8" drill bit where you made the pencil marks. Now install the Top Channel in place using #8 x 1 1/2" screws.

Step 3 Installing the Bottom Track

A. Determine the type of flooring for this installation:

1. Carpet

It is highly recommended that if you have carpet and do not have a cut-out in the carpet already, you should cut the carpet in order to install the Bottom Track directly to the floor. Use the utility blade to make a straight cut. We do not recommend installing the Bottom Track directly on top of carpet or padding.

2. Concrete

Use Concrete Nails to attach Wood Strip to floor. Or, you may glue the Wood Strip down with construction adhesive (not included).

3. Tile

Drill holes with a 3/16" masonry drill bit. Insert screw anchors and attach Wood Strip to floor with screws. Or, you may glue the Wood Strip down with construction adhesive. (Screws, anchors and adhesive are not included.)

4. Wood

Use Penny Nails to attach Wood Strip to wood floor.

B. Measure opening at the bottom from wall to wall.

Note: If the baseboard molding continues into the opening, you may need to remove it so that the wardrobe doors will close flush to the wall.

C. Cut the new Bottom Track and Wood Strip to this dimension.

D. Find the correct offset measurement, using the offset measurement chart, for your particular model. From the front edge of the opening, measure using the offset from the chart and make a small pencil mark on the wall. Do this on both walls, i.e., right and left walls (See **Figure 2**).

Offset measurement chart

Measurements (see chart below) will be from face of opening to front edge of Wood Strip.

Note: For optional Mirror or Painted Glass Fascia, add 1/4" to the Bottom Track offset measurement.

Model	Offset
Aristocrat™/Golden Oak™	2 1/4"
Aspen™/Econoline™/Colonial™/Savoy™/Tundra™	1 1/2"
Aurora™/Aurora™ Plus	1 1/2"
Brittany®	1 3/8"
California Oak™	2 1/4"
Concord™/Sequoia®	1 1/2"
Eclipse®	1 1/2"
Fantasy IV®/Asprey®	1 3/4"
Majestic™	2"
Oak Fantasy®	2 1/4"
Pacifica®/Tudor®	1 1/2"
Royal Oak®/Royal Maple™	2 1/4"
Serenity™/Tranquility™	1 5/8"
Style Lite®	1 5/8"
Trim Line®	1 1/2"

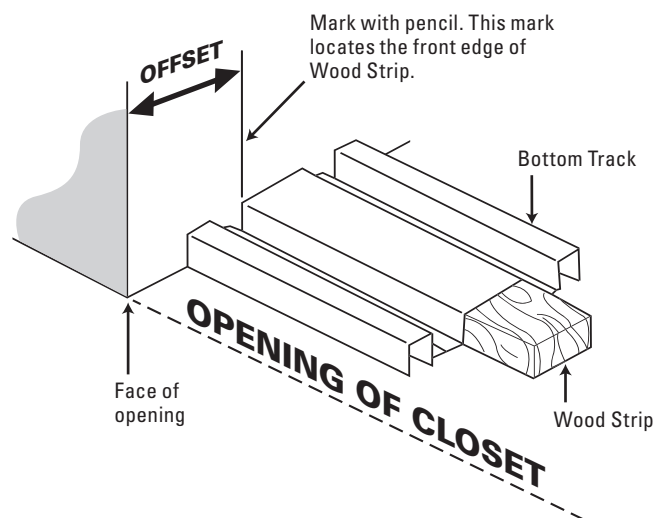

Figure 2

E. Place the front of the Wood Strip up to the pencil mark on wall (See **Figure 3**). Do this on both sides. Install the Wood Strip.

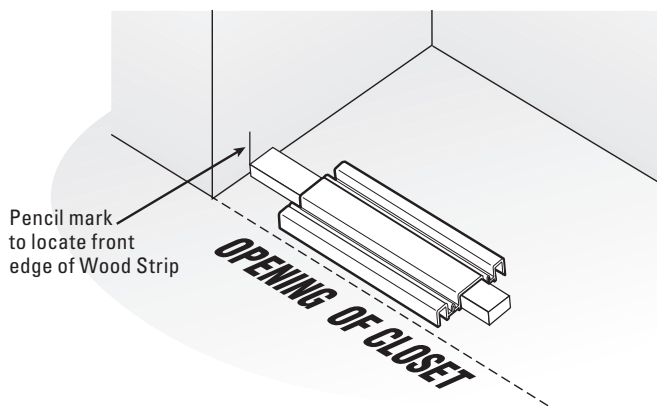

Figure 3

F. Cut the Bottom Track to your measurement of the inside closet opening. Place the Bottom Track over the Wood Strip and attach with four #8 x 1/2" Truss Screws.

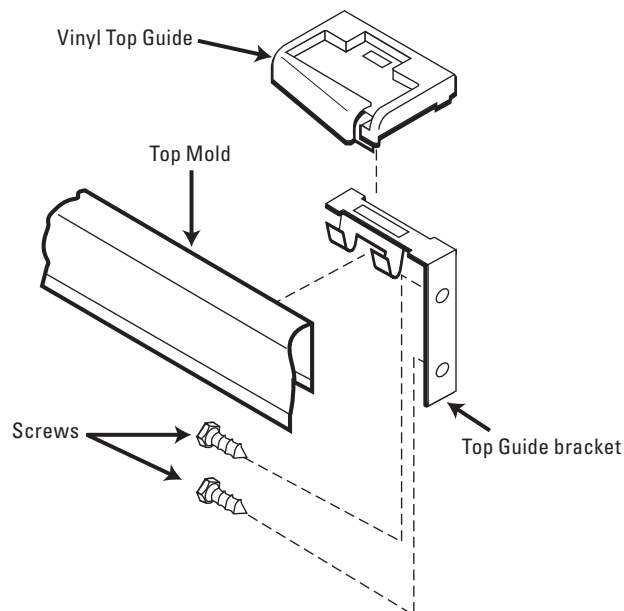

Figure 4

C. Pick up one Door Panel and, with the finished side front facing you, tilt the top of the Door Panel back and slip the Door Panel into the back runner of the Top Channel. Next, set the bottom of the Door Panel into the back runner of the Bottom Track.

D. For the front Door Panel, repeat C, but place the Door Panel into the front runner of the Top Channel and the front runner of the Bottom Track.

Step 4 Installing the Door Panels

A. Make sure you have a pad or blanket to protect the Door Panels from scratches. Lay the Door Panels on the floor with the back side up. Locate one of the Wheel Assemblies on the bottom of a Door Panel. With a phillips screwdriver, turn the adjusting screw clockwise to lower the roller. Do this until you have 1" of roller showing. Adjust both Wheel Assemblies on each Door Panel (This will avoid scratching the Bottom Track when installing the Door Panels).

B. For Aspen™, Econoline™, Colonial™ and Savoy™ models, insert Vinyl Top Guides into Top Guide Bracket on top of Door Panels by firmly snapping into place. Please refer to your Illustrated Parts Breakdown (IPB) drawing associated to your specific model (See **Figure 4**).

Note: Top Guides can be found in a bag attached to the back of each Panel.

Step 5 Adjusting the Door Panels

A. For models with exposed Wheel Assemblies

Slide the front Door Panel to the side closest to the room's entrance door (this is how the wardrobe doors will be in position to look their best). Look at the space between the door edge and the wall. You want the door edge and the wall to be flush. If you see space at the top or bottom edge of the Door Panel, turn the adjusting screw on top of the Wheel Assembly on the back of the Door Panel nearest the wall (See **Figure 5**). Turn the screw counterclockwise or clockwise until the Door Panel aligns flush with the wall. Repeat for each Door Panel.

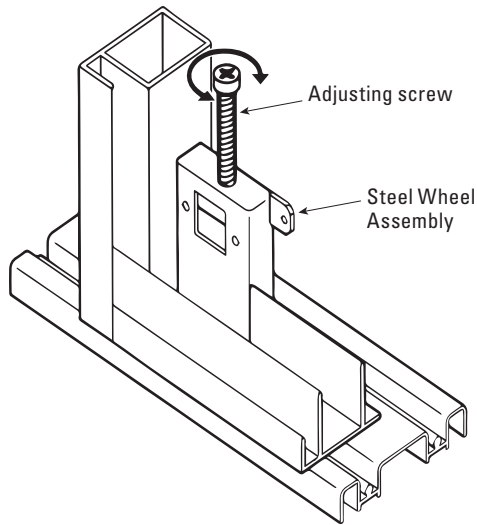

Figure 5

B. For models with concealed Wheel Assemblies

If you see space at the top or bottom edge of the Door Panel, turn the adjusting screw through the adjustment hole at the bottom of the Door Panel nearest the wall. Turn the screw counterclockwise or clockwise until the Door Panel aligns flush with the wall. Repeat for each Door Panel (See **Figure 6**).

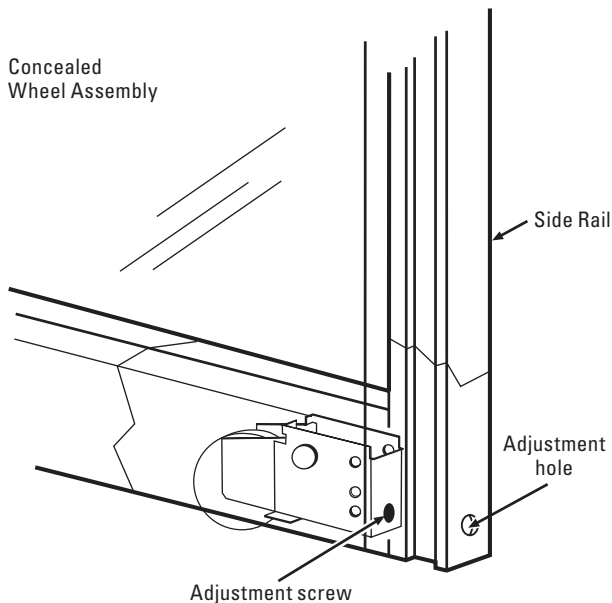

Figure 6

Step 6 Installing the Mirror Handles

For Door Panels with Mirror Handles (Asprey®, Aurora™, Brittany®, Fantasy IV®, Style Lite® and Trim Line®)

A. Clean Mirror in the area where the Mirror Handles will be applied. Peel film off the back of the Mirror Handles. Position each Mirror Handle 36" from the bottom of the Door Panel and 1-1/2" from the Side Mold on each Door Panel (See **Figure 7**).

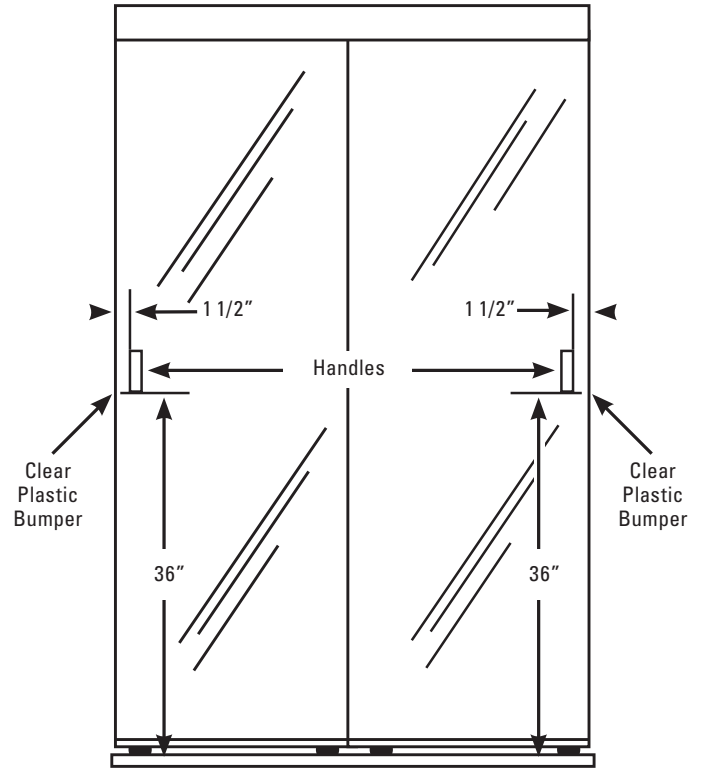

Figure 7

B. If there are three Door Panels, place one Mirror Handle on the left side of the center Door Panel, and another Mirror Handle on the right side of the center Door Panel.

Step 7 Installing the Bumpers

A. Peel film off the back of the Clear Plastic Bumpers and place on the edge of the Door Panel frame 36" up from the bottom of the Door Panel. The Clear Plastic Bumpers will cushion and protect the door and wall when you close the wardrobe doors (See **Figure 7**).

B. For **Eclipse®**, peel the paper off the back of the Bumpers. Insert the top and bottom Bumpers by aligning the holes and firmly pressing them into place (See **Figure 8**).

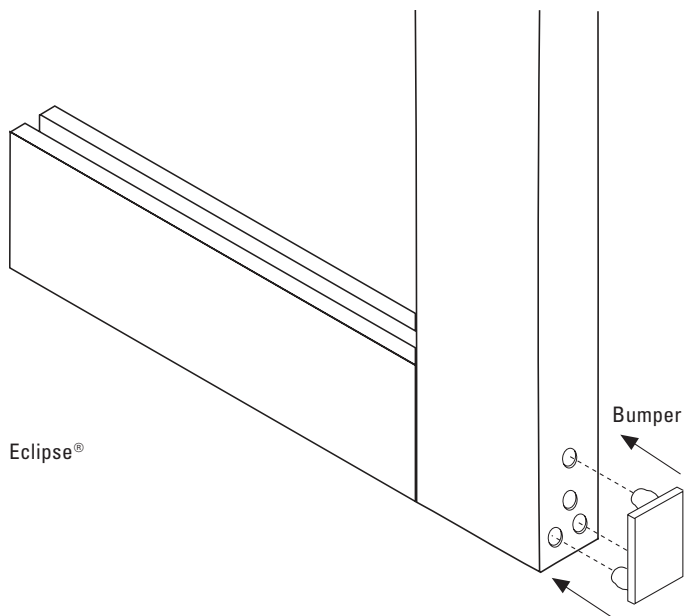

Figure 8

Thank you for making Cw® a part of your home. We invite you to visit our website at CwDoors.com for more information about our extensive line of wardrobe doors, room partitions and loft dividers, cabinet doors and shower enclosures. Our line of products features Duratuf® tempered safety glass, painted glass, CwShield™ protective coating and Duraflect® copper-free mirrors.

Visit us at
CwDoors.com
for other quality Cw[®] products

